

Model 4600 & 4602 Accelerometer



Advanced Temp Compensation
Gas Damped, DC Response
Amplified, Signal Conditioned
MEMS Accelerometer

The Model 4600 & 4602 are designed for both static and dynamic measurements in critical and demanding applications. The accelerometers are available in ranges from ± 2 to $\pm 500g$ and offers outstanding thermal performance. The model 4600 is temperature compensated from -40°C to $+100^{\circ}\text{C}$ while the model 4602 is compensated from -55°C to $+125^{\circ}\text{C}$. The accelerometers incorporate a gas damped MEMS sensing element with integral over-range stops for high-g shock protection.

FEATURES

- $\pm 2g$ to $\pm 500g$ Dynamic Range
- Amplified Output
- Low Power Consumption
- Gas Damping
- Integral Strain Relief
- DC, Low Frequency Response
- 8 to 36Vdc Excitation Voltage

APPLICATIONS

- Flight Testing
- Flutter and Nacelle Vibrations
- Road Vehicle Testing
- Structural Testing
- Test and Instrumentation
- Performance Testing
- Transportation



dimensions

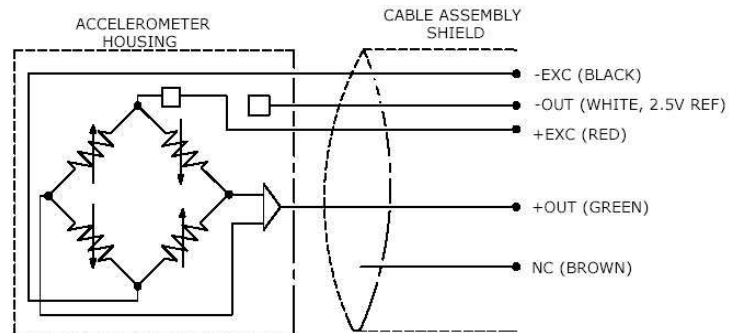
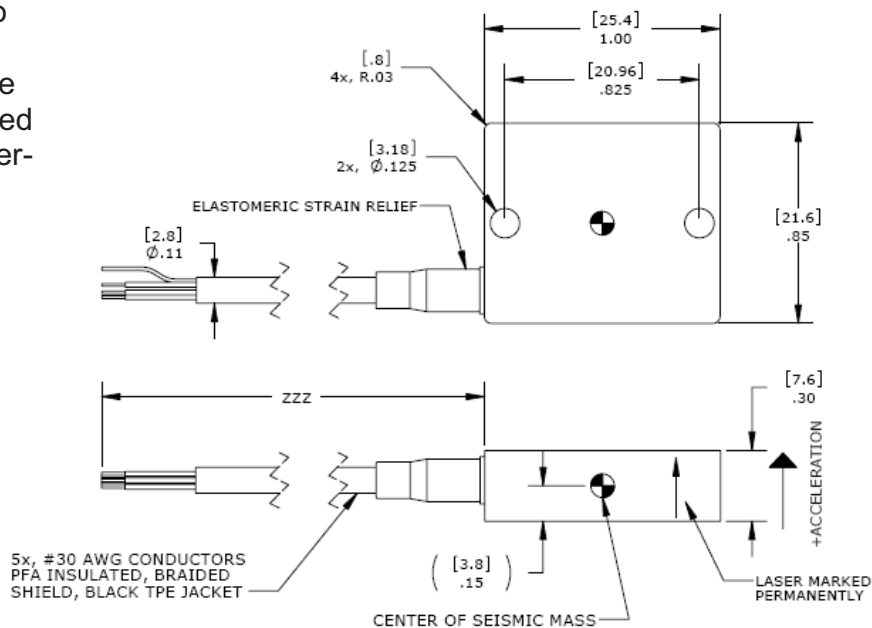

Model 4600 & 4602 Accelerometer

performance specifications

All values are typical at +24°C, 100Hz and 12Vdc excitation unless otherwise stated. Measurement Specialties reserves the right to update and change these specifications without notice.

Parameters

DYNAMIC								Notes
Range (g)	±2	±10	±30	±50	±100	±200	±500	
Sensitivity (mV/g)	1000	200	67	40	20	10	4	
Frequency Response (Hz)	0-200	0-400	0-700	0-1000	0-1500	0-1500	0-1500	±5% ¹
Frequency Response (Hz)	0-400	0-600	0-1000	0-1600	0-2000	0-2000	0-2000	±1dB
Natural Frequency (Hz)	700	1000	1500	4000	6000	8000	10000	
Non-Linearity (%FSO)	±0.5	±0.5	±0.5	±0.5	±0.5	±0.5	±0.5	
Transverse Sensitivity (%)	<2	<2	<2	<2	<2	<2	<2	<1 Typical
Damping Ratio	0.7	0.7	0.7	0.7	0.7	0.6	0.5	
Shock Limit (g)	10000	10000	10000	10000	10000	10000	10000	

ELECTRICAL

Zero Acceleration Output (mV)	±50	±50	±50	±50	±50	±50	±50	Differential
Excitation Voltage (Vdc)	8 to 36	8 to 36	8 to 36	8 to 36	8 to 36	8 to 36	8 to 36	
Excitation Current (mA)	<5	<5	<5	<5	<5	<5	<5	
Bias Voltage (Vdc)	2.5	2.5	2.5	2.5	2.5	2.5	2.5	
Output Resistance (Ω)	<100	<100	<100	<100	<100	<100	<100	
Insulation Resistance (MΩ)	>100	>100	>100	>100	>100	>100	>100	@100Vdc
Turn On Time (msec)	<100	<100	<100	<100	<100	<100	<100	
Residual Noise (µV RMS)	500	300	350	400	400	400	400	Passband
Spectral Noise (µg/√Hz)	35	75	197	316	516	1033	2582	Passband
Ground Isolation	Isolated from Mounting Surface							

ENVIRONMENTAL

Thermal Zero Shift (%FSO/°C)	±0.008	±0.008	±0.008	±0.008	±0.008	±0.008	±0.008	Typical
Thermal Sensitivity Shift (%/°C)	±0.010	±0.010	±0.010	±0.010	±0.010	±0.010	±0.010	Typical
Operating Temperature (°C)	-55 to 125							
Compensated Temperature (°C)	-40 to 100 for Model 4600							
Compensated Temperature (°C)	-55 to 125 for Model 4602							
Storage Temperature (°C)	-55 to 125							

PHYSICAL

Case Material	Anodized Aluminum
Cable	Teflon Insulated Leads, Braided Shield, TPE Jacket
Weight (grams)	8
Mounting	2x #4 or M3 Screws
Mounting Torque	6 lb-in (0.7 N-m)
AWG	#30

Wiring color code: +Excitation = Red; -Excitation = Black; +Output = Green; -Output = White; Programming = Brown (brown wire is used for programming and is not to be connected)

Calibration supplied: CS-FREQ-0100 NIST Traceable Amplitude Calibration from 20Hz to ±5% Frequency Response Limit¹

Supplied accessories: AC-A02285 2x #4-40 (7/16 length) Socket Head Cap Screw and Washer

Optional accessories: AC-D02669 Triaxial Mounting Block
101 Three Channel DC Signal Conditioner Amplifier

The information in this sheet has been carefully reviewed and is believed to be accurate; however, no responsibility is assumed for inaccuracies. Furthermore, this information does not convey to the purchaser of such devices any license under the patent rights to the manufacturer. Measurement Specialties, Inc. reserves the right to make changes without further notice to any product herein. Measurement Specialties, Inc. makes no warranty, representation or guarantee regarding the suitability of its product for any particular purpose, nor does Measurement Specialties, Inc. assume any liability arising out of the application or use of any product or circuit and specifically disclaims any and all liability, including without limitation consequential or incidental damages. Typical parameters can and do vary in different applications. All operating parameters must be validated for each customer application by customer's technical experts. Measurement Specialties, Inc. does not convey any license under its patent rights nor the rights of others.

Model 4600 & 4602 Accelerometer

performance specifications

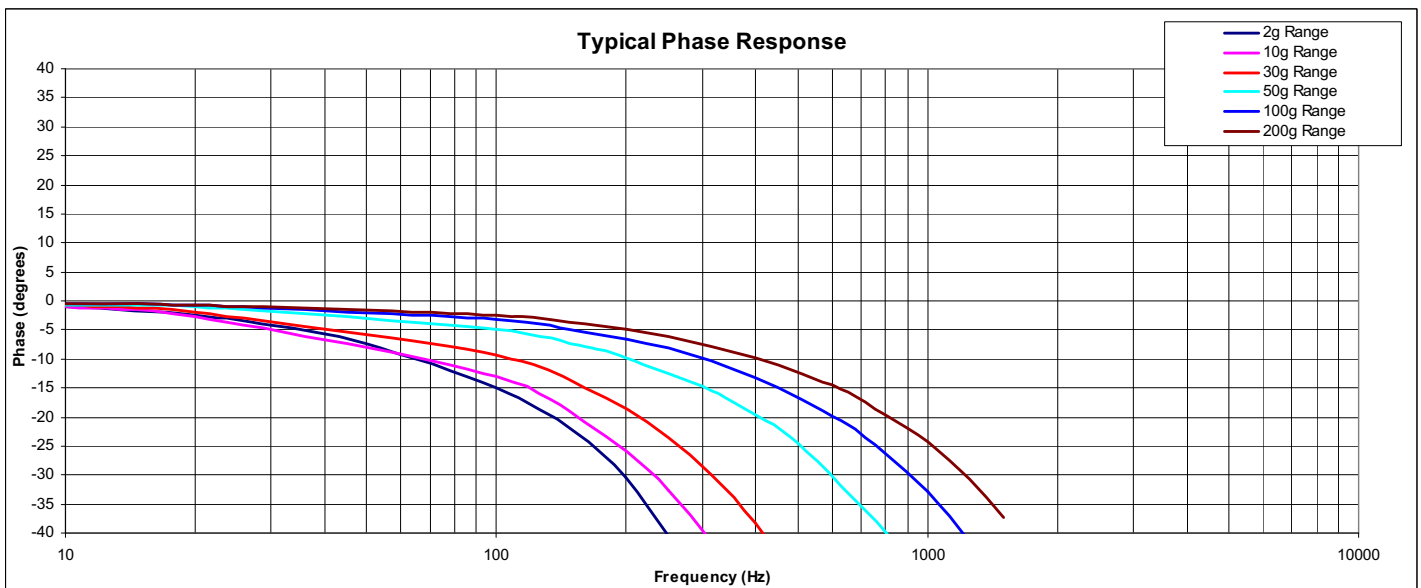
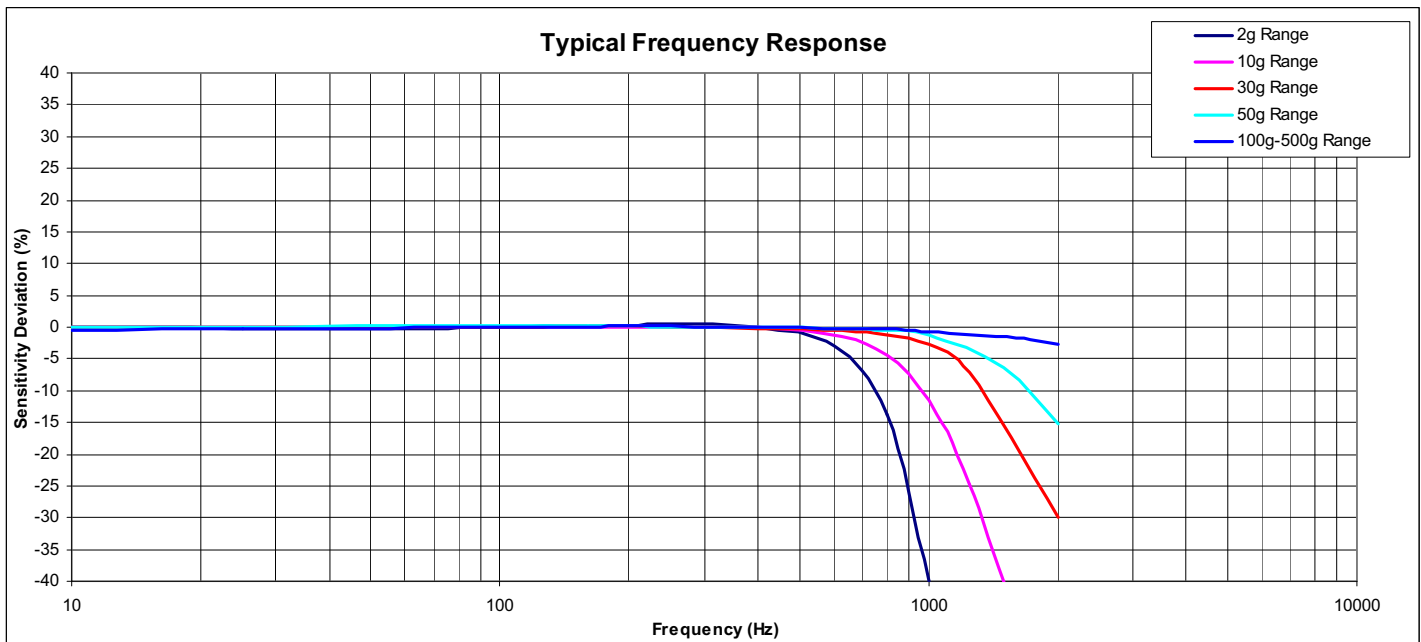

ordering info

PART NUMBERING Model Number+Range+Cable Length

4600-GGG-CCC

| | | Cable (060 is 60 inches)

| | Range (010 is 10g)

| Model (4600, -40°C to +100°C temp compensation)
(4602, -55°C to +125°C temp compensation)

Example: 4600-010-060

Model 4600, 10g, 060" (5ft) Cable